

HARMONIC GEARHEAD

Nexen's revolutionary Harmonic Gearhead (HG) is the perfect combination of size and precision. Use the Harmonic Gearhead integrated with Nexen's RPS Pinion (HGP) to create a true backlash-free solution from the motor to the driven load. With up to a 70% reduction in length over standard gearheads, machine designers will appreciate the opportunities available with this space saving product.

Features & Benefits	40
Specifications	41
Selection Process	
Cycle Determination	42
Stiffness	43
Output Loading	44–45
Efficiency	46
Dimensional Drawings	47
Life Graphs	48
Input Motor	48
HGP Preloader	49–50



PATENTED

The Nexen Harmonic Gearhead Advantage

Nexen's patent pending Harmonic Gearhead (HG) offers a precision drive solution that overcomes the challenges of existing gearing methods. This new technology eliminates problems with backlash that have plagued the motion control industry, offering reliable precision even when intricate movements are required.

In the tradition of Nexen's entire line of precision motion control products, the Harmonic Gearhead sets new standards with these great features:

- **Zero Backlash**
- **High Positional Accuracy & Repeatability**
- **Quiet Operation**
- **Large, Rugged Cross-Roller Output Bearing**
- **Compact**

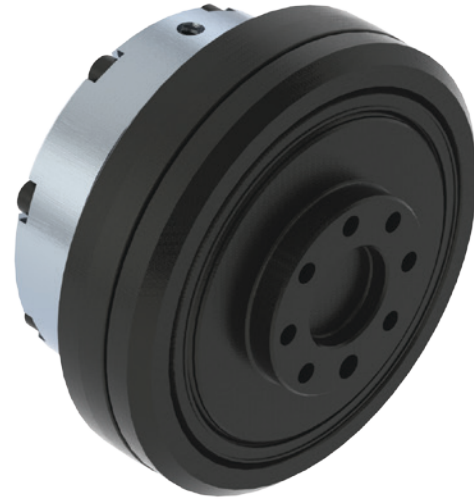

Save 70% or more in gearhead length.

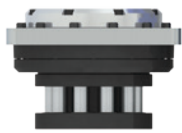

HGP

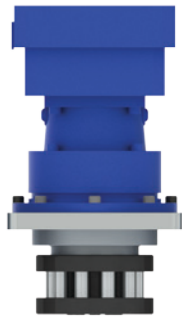

Standard Two-Stage Planetary

Harmonic Gearhead with Pinion

Save space by taking advantage of Nexen's Harmonic Gearhead with Pinion (HGP).

In this model, the RPS pinion comes fully integrated into the gearhead, creating the only drive solution that maintains **zero backlash** from the driving motor shaft through to the driven load for both linear and rotary motion.

DRIVING TECHNOLOGY IN ADVANCING MARKETS

Nexen's HG(P) utilizes Harmonic Strain-Wave Technology made up of a circular spline, flex-spline and wave generator. As these components rotate, their unique shape and tooth profile allow 30% of the teeth to be engaged simultaneously for:

Smooth Rotation • High Torque • Zero Backlash

The effortless, low-stress meshing of the circular spline and flex-spline teeth results in a long gearhead life with reliable, quiet operation. Some operators call this peace of mind.

Aerospace

Robotics

Semiconductor

Factory Automation

Medical / Surgical

Harmonic Gearhead Specifications

HARMONIC GEARHEAD (HG)

Specifications		HG17				HG25				HG32				HG50		
Gear Ratio		50:1	80:1	100:1	120:1	50:1	80:1	100:1	120:1	50:1	80:1	100:1	120:1	80:1	100:1	120:1
Max Acceleration Torque ¹	Nm	35	35	51	51	72	113	140	140	140	217	281	281	675	866	1057
Max Average Torque ¹	Nm	25	30	35	35	51	85	90	90	100	153	178	178	484	611	688
Inertia at Input	kg-cm ²	0.1959	0.1954	0.1952	0.1952	0.7522	0.7503	0.7498	0.7496	2.6294	2.6236	2.6222	2.6215	20.485	20.467	20.457
Backlash	ArcSec	0				0				0				0		
One Way Accuracy	±ArcSec	45				45				45				45		
One Way Repeatability	±ArcSec	10				10				10				10		
Weight	kg	1.4				2.6				5.2				20.0		
Product Number		969000	969001	969002	969003	969040	969041	969042	969043	969060	969061	969062	969063	969100	969101	969102

HARMONIC GEARHEAD WITH PINION (HGP)

Specifications		HGP17				HGP25				HGP32				HGP50		
Integrated Pinion Size		RPS16				RPS20				RPS25				RPS40		
Gear Ratio		50:1	80:1	100:1	120:1	50:1	80:1	100:1	120:1	50:1	80:1	100:1	120:1	80:1	100:1	120:1
Max Acceleration ¹	Torque (Nm)	35	35	51	51	72	92	92	92	140	159	159	159	458		
	Thrust (N)	1374	1374	2003	2003	2262	2900	2900	2900	3519	4000	4000	4000	6000		
Max Average ¹	Torque (Nm)	25	30	35	35	51	85	90	90	100	153	159	159	458		
	Thrust (N)	982	1178	1374	1374	1602	2670	2827	2827	2513	3845	4000	4000	6000		
Inertia at Input	kg-cm ²	0.1971	0.1958	0.1955	0.1954	0.7538	0.7509	0.7502	0.7499	2.6326	2.6248	2.6230	2.6221	20.518	20.488	20.471
Backlash	µm	0				0				0				0		
One Way Accuracy	± µm	25				25				25				25		
One Way Repeatability	± µm	7.5				7.5				7.5				7.5		
Weight	kg	1.7				3.0				5.8				24.8		
Product Number		969010	969011	969012	969013	969050	969051	969052	969053	969070	969071	969072	969073	969110	969111	969112

GENERAL SPECIFICATIONS FOR BOTH HG & HGP UNITS

Specifications		Size 17	Size 25	Size 32	Size 50
Max Input Speed ¹	cyclic RPM	7300	5600	4800	3500
	continuous RPM	3650	3500	3500	2500
Max Average Input Speed ¹	RPM	3650	3500	3500	2500
Max Input Acceleration Rate	rad/sec ²	5100	3900	3350	2450
Efficiency @ Max Average Torque (E _{T,max})		80% ±5%			
Stiffness, Hysteresis		See <i>Stiffness</i> Section			
Output Loading		See <i>Output Loading</i> Section			
Temperature Limits		Ambient Temperature: 0°C to +40°C Maximum Unit Temperature: < 90°C			
Mounting Position		No Restriction			
Direction of Rotation		Motor Opposite Gearhead			
Lubrication		Lubricated for Life			
Life		See <i>HG & HGP Life</i> Section			

¹ Refer to the *Harmonic Gearhead Selection Process* section for product sizing procedures.

Note: All accuracy data taken at 2% of maximum load.

Harmonic Gearhead Selection Process

When selecting the proper Harmonic Gearhead, use the Specifications table to determine the HG/HGP size that best fits the application's torque, speed and physical size requirements. Then, use the following calculation sections to evaluate whether the cycle type, stiffness, efficiency and bearing load capacity of the selected HG/HGP size meets all the application requirements.

HG/HGP Cycle Determination

Correct sizing of the Harmonic Gearhead is critical to the proper function and life expectancy of your unit. The following section provides information regarding cycle type to be used in the gearhead sizing process. The two Cycle Types are: **Continuous Motion & Cyclic Motion**

STEP 1: Determine which Cycle Type applies to your application.

STEP 2: Use the *Cycle Limitations* information to correctly size the Gearhead.

CONTINUOUS MOTION: single direction motion lasting longer than one hour

Cycle Limitations	
Input Speed	Max average input speed
Output Torque	Max average torque

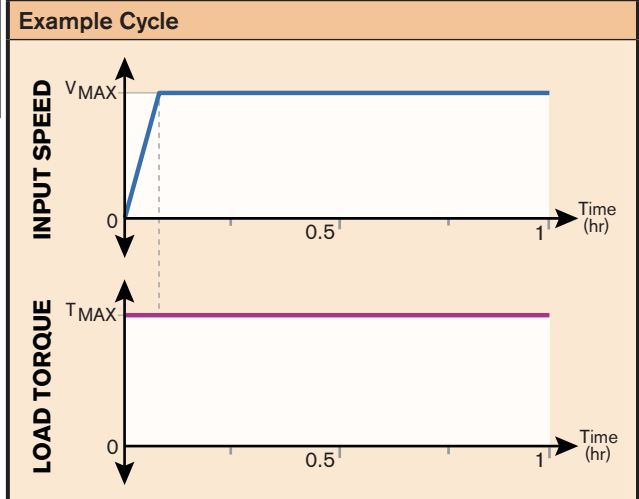

CYCLIC MOTION: reversing direction motion

Cycle Limitations	
Input Speed	Time at Max Input Speed ≤ 10 seconds (t_2)
	Time above Max Average Input Speed ≤ 30 seconds (t_1)
	Average over any 2 minutes \leq Max Average Input Speed
Output Torque	Time at Max Acceleration Torque ≤ 10 seconds (t_3)
	Time above Max Average Torque ≤ 10 seconds
	Average over any 2 minutes \leq Max Average Torque

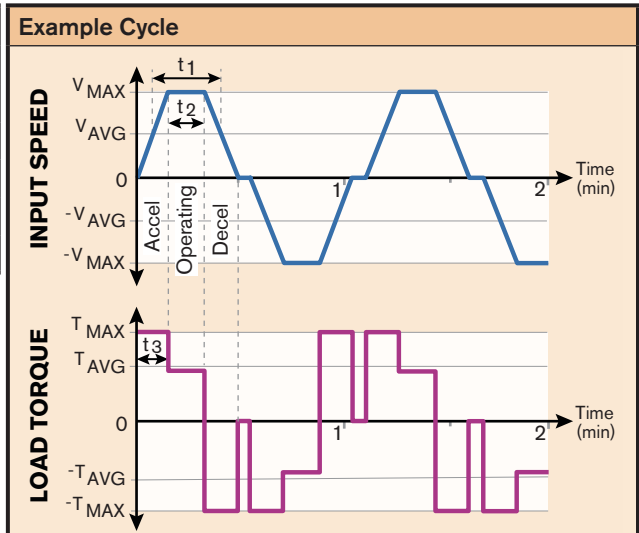

HG/HGP Torsional Stiffness

Unlike many other gearing types, Harmonic Gearhead stiffness is non-linear. As torque increases, stiffness also increases, as shown in the graph below. NOTE: If you wish to calculate "windup" at torque greater than T1, remember to include the displacement caused by lower stiffness regions.

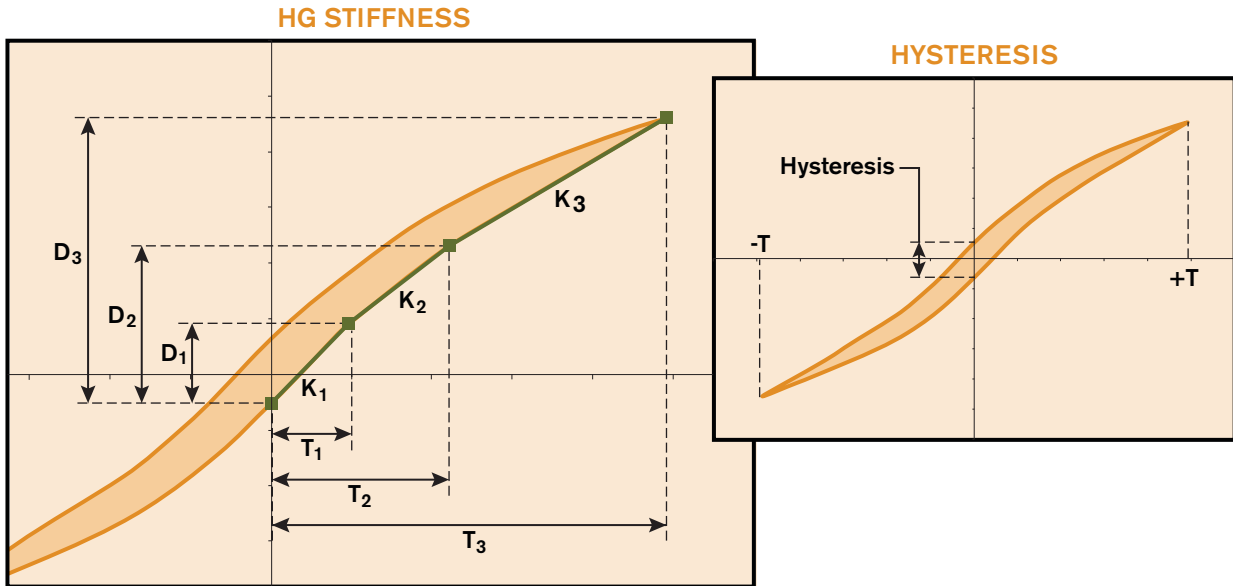

HG AND HGP STIFFNESS DATA

Torsional stiffness is determined by applying a torque to the output of the gearhead while the input is held from rotation. For ease of calculation, the slope of the curve is approximated using three straight lines representing stiffness values K_1 , K_2 , & K_3 .

Refer to the tables below for the typical stiffness values for each size HG and HGP.

	Reference Torque (Nm)	Ref. Disp. (ArcMin)		Stiffness (Nm/ArcMin)	
		50:1	80:1 +	50:1	80:1 +
Size 17	T ₁	3.9	D ₁ 1.66 1.44	K ₁ 2.36 2.70	
	T ₂	8.0	D ₂ 2.94 2.81	K ₂ 3.20 3.00	
	T ₃	35.0	D ₃ 10.08 10.99	K ₃ 3.78 3.30	
Size 25	T ₁	14.0	D ₁ 2.00 2.12	K ₁ 7.00 6.60	
	T ₂	48.0	D ₂ 6.53 6.98	K ₂ 7.50 7.00	
	T ₃	90	D ₃ 11.20 11.98	K ₃ 9.00 8.40	

	Reference Torque (Nm)	Ref. Disp. (ArcMin)		Stiffness (Nm/ArcMin)	
		50:1	80:1 +	50:1	80:1 +
Size 32	T ₁	52.0	D ₁ 3.11 2.81	K ₁ 16.70 18.50	
	T ₂	108.0	D ₂ 6.06 4.81	K ₂ 19.00 28.00	
	T ₃	178.0	D ₃ 8.52 6.93	K ₃ 28.50 33.00	
Size 50	T ₁	108.0	D ₁ NA 1.66	K ₁ NA 65.00	
	T ₂	382.0	D ₂ NA 5.81	K ₂ NA 66.00	
	T ₃	688.0	D ₃ NA 10.38	K ₃ NA 67.00	

HYSTERESIS

Hysteresis is measured by applying maximum average torque in both directions on the output with the input locked. Typical values are provided in the table to the right.

Hysteresis (ArcSec)			
Size 17	Size 25	Size 32	Size 50
90	90	60	60

HG Output Loading

Harmonic Gearheads come equipped with a cross roller bearing on the output, offering high precision and large, load-carrying capabilities. Use the following information to verify that the selected gearhead meets all application load requirements.

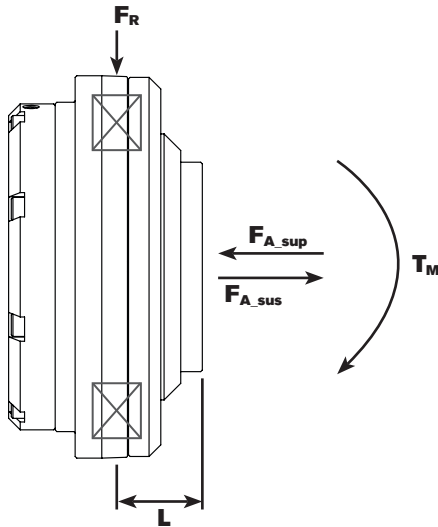

Table 9

Harmonic Gearhead Output Load Ratings Table					
		HG(P)17	HG(P)25	HG(P)32	HG(P)50
Bearing Constant (C_B)	m^{-1}	31.25	23.81	18.52	11.90
Bearing Center Distance to Flange (L)	m	0.0185	0.0255	0.029	0.0425
Max Axial Suspended Load ($F_{A_sus_max}$)	N	450	1100	1550	4500
Max Axial Supported Load ($F_{A_sup_max}$)	N	10100	11700	19000	45400
Max Radial Load (F_{R_max})	N	2220	3180	4220	12200
Max Moment Load (T_{M_max})	Nm	170	270	450	1590
Max Combined Load (P_{C_max})	N	6800	7900	12800	30450

Single vs. Multiple Load Direction

SINGLE LOADING DIRECTION

If only one loading direction applies to your application, simply compare the maximum application load with the HG ratings above to ensure that the gearhead is capable of withstanding the application load.

MULTIPLE LOADING DIRECTIONS

When two or more loading directions apply, calculate the combined load using radial, axial and moment load values. Record your application data and perform the calculations on the following page to determine the Combined Load (P_C) of your application. Then compare this value with the Max Combined Load in Table 9 above.

NOTE: Although Combined Load is calculated using average loads, no load should exceed the maximum rated load for that loading direction.

HG Output Loading (continued)

CALCULATING COMBINED LOAD REQUIREMENTS

Refer to the explanations and data on the preceding page to complete the following calculations to determine the combined load requirements of your application.

STEP 1: GATHER APPLICATION DATA

Axial (F_A), Radial (F_R), and Moment (T_M) Loads are application specific. Use the table below to record the average loads that the gearhead will be subjected to during operation.

Application Loads Required for Gearhead Selection	Customer Application Data (record your values below)	Sample Data (HG25)	Sample Application
Average Axial Load (F_A) [Either suspended (F_{A_sus}) or supported (F_{A_sup}), whichever is present in your application]	N	1000 N (F_{A_sup})	
Average Radial Load (F_R)	N	500 N	
Average Moment Load (T_M)	Nm	250 Nm	

STEP 2: CALCULATE COMBINED LOAD ON BEARING

Calculating a Combined Load simplifies a complex load scenario into a single value that characterizes the application and can be compared to the Maximum Combined Load (P_{C_max}) in the ratings table. Follow the steps below to find the Combined Load that characterizes your application.

RADIAL/MOMENT LOAD (F_{RM}):
 $F_{RM} = F_R + (C_B \cdot T_M)$ $F_{RM} =$ N + ($m^{-1} \cdot$ Nm)

Sample: $F_{RM} = 500\text{ N} + (23.81\text{ m}^{-1} \cdot 250\text{ Nm}) = 6452.5\text{ N}$

RADIAL/MOMENT LOAD (F_{RM})

$F_{RM} =$ N

<p>Use this table to determine the correct value for X & Y to be used in the Combined Load equation below.</p>	$\frac{F_A}{F_{RM}} = \frac{\text{N}}{\text{N}} =$ <input type="text"/>	IF:	THEN:	
			X	Y
		$\frac{F_A}{F_{RM}} \leq 1.5$	1	0.45
	$\frac{F_A}{F_{RM}} > 1.5$	0.67	0.67	

Sample: $1000\text{ N} \div 6452.5\text{ N} = 0.155$ So, X = 1 & Y = 0.45

COMBINED LOAD (P_C):
 $P_C = (X \cdot F_{RM}) + (Y \cdot F_A)$ $P_C =$ (\cdot N) + (\cdot N)

Sample: $P_C = (1 \cdot 6452.5\text{ N}) + (0.45 \cdot 1000\text{ N}) = 6902.5\text{ N}$

COMBINED LOAD (P_C)

$P_C =$ N

STEP 3: VERIFY APPROPRIATE HG SIZE

Compare the calculated Combined Load (P_C) value with the Max Combined Load (P_{C_max}) found in Table 9 to verify whether the selected HG size meets your application load requirements.

NOTE: Consult Nexen if application subjects the HG output to significant vibrations or impact loading.

HG / HGP Efficiency

Gearhead efficiency is dependent on many factors, including temperature, speed, torque, and lubrication type. However, the biggest contributor to efficiency loss is running torque, therefore the following calculations focus on your application torque. As is true with any system, efficiency calculations are merely estimations and should be treated as such.

STEP 1: CALCULATE THE TORQUE RATIO

To find the Torque Ratio, divide your application torque by the maximum average torque.

- Refer to the HG Specifications Table to find max average torque values.
- Determine the torque on which you want to base your efficiency ratings.

APPLICATION TORQUE (T_{AP})	MAX TORQUE (T_{MAX})
<input type="text"/>	<input type="text"/>
Sample: 12 Nm	Sample: 25 Nm

TORQUE RATIO: $R = \frac{T_{AP}}{T_{max}}$ $R = \frac{\quad}{\quad}$ TORQUE RATIO: $R = \quad$

Sample: $R = 12 \div 25 = 0.48$

STEP 2: FIND THE EFFICIENCY COMPENSATION COEFFICIENT (C_E)

Use the graph below to determine the Compensation Coefficient (C_E).

- Mark on the x-axis the Torque Ratio (R) value calculated in Step One.
- Draw a vertical line from this point until it intersects the curve.
- From the intersection point marked on the curve, draw a horizontal line to the y-axis.
- Record the value at this y-axis intersection point as the Compensation Coefficient (C_E).

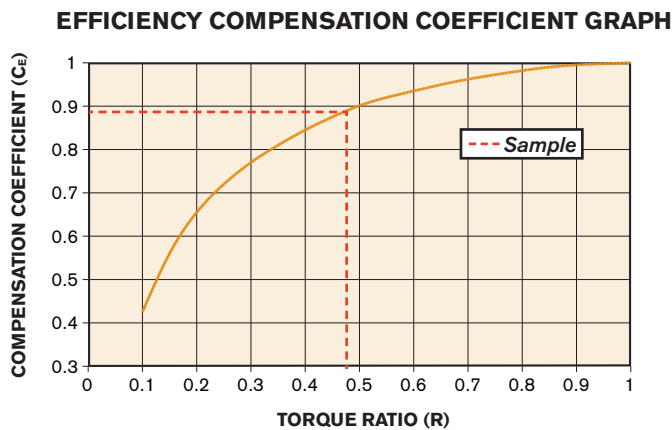

COMPENSATION COEFFICIENT
$C_E = \quad$
Sample: $C_E = 0.88$

STEP 3: CALCULATE EXPECTED APPLICATION EFFICIENCY

To find the expected efficiency at your application torque, simply multiply the Efficiency Compensation Coefficient (C_E) by the Efficiency at Max Torque ($E_{T_{max}}$).

- Refer to the HG Specifications table to find the $E_{T_{max}}$ value and record it in the equation below.

EXPECTED APPLICATION EFFICIENCY
EXPECTED APPLICATION EFFICIENCY: $E_A = C_E \cdot E_{T_{max}}$ $E_A = \quad \cdot \quad \%$ $E_A = \quad \%$
Sample: $E_A = 0.88 \cdot 80\% = 70.4\%$

Harmonic Gearhead Dimensional Drawings

SAMPLE INPUT CONFIGURATION

Input can be configured for user servomotor. Contact Nexen.

All dimensions shown in mm.

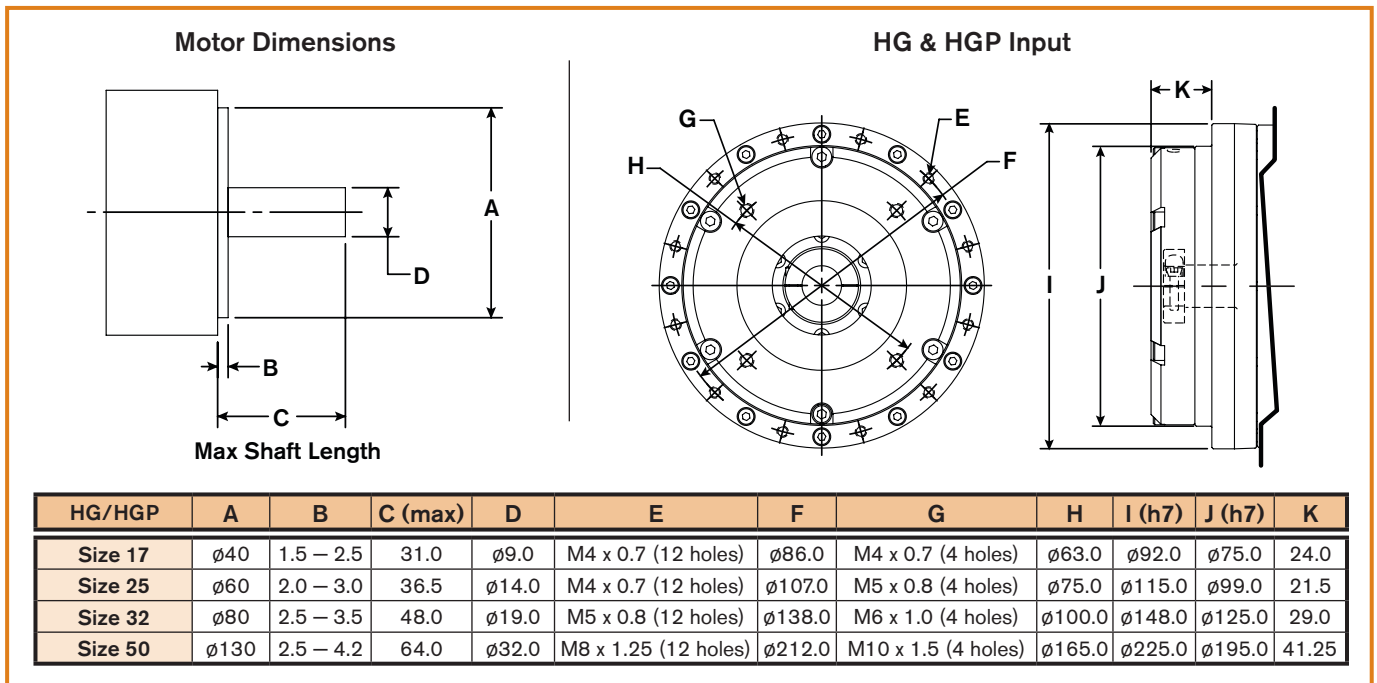

OUTPUT CONFIGURATION

All dimensions shown in mm.

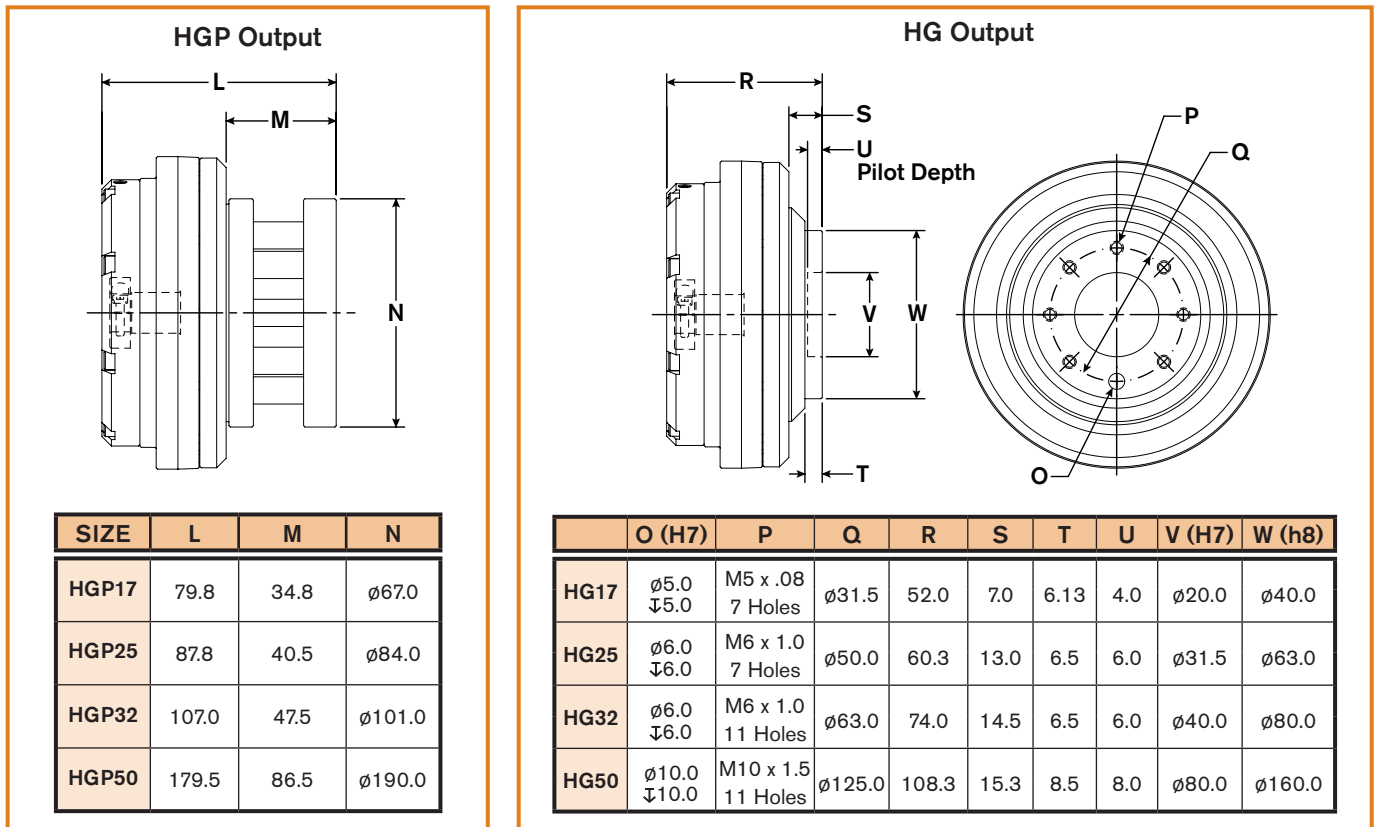

HG & HGP Life

Harmonic Gearhead life is based on average output torque and ratio.

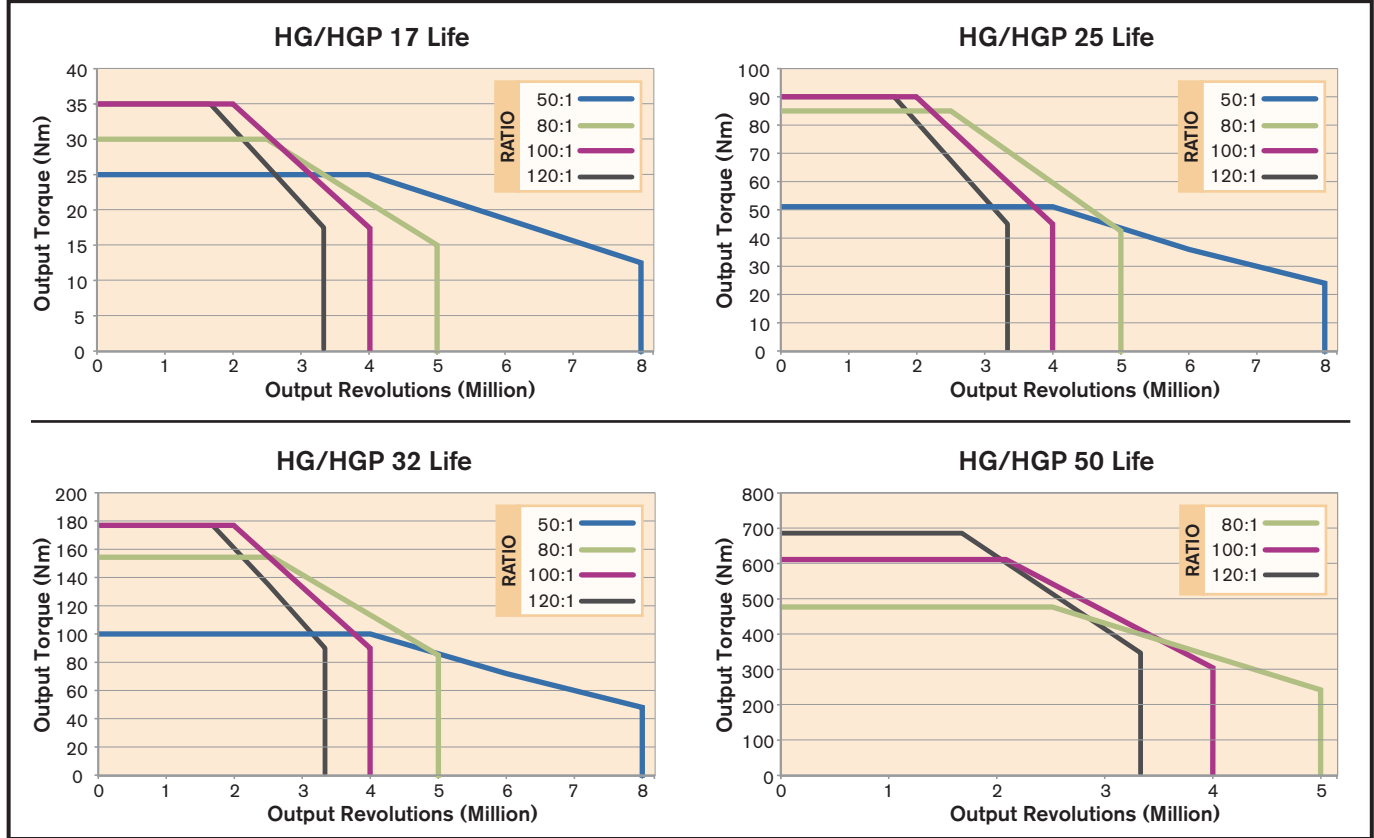

Input Motor Recommendations

Allowable Motor Tilting Torque

Allowable motor tilting torque is defined as the combination of static and dynamic force acting through the motor's center of gravity, multiplied by the distance (d_{CG}) to the HG motor adaptor mounting face.

NOTE: DO NOT subject the input coupling to an overhung load (example: pulley, sheave, etc.).

HG(P) Size	Torque (Nm)
17	20
25	40
32	80
50	200

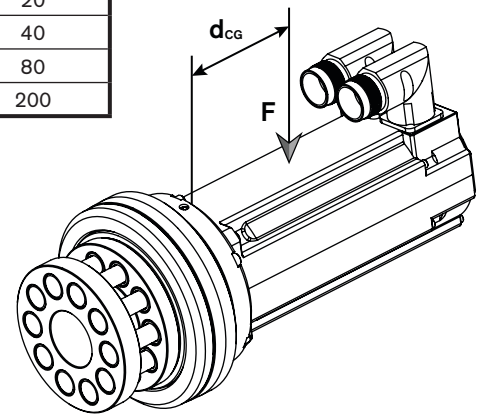

Input Sealing

A gasket seal is positioned between the motor adaptor and the motor pilot to help seal the HG product from external dust and debris. Be sure to use a properly sized servo motor input flange. A servo motor with an oil seal on the output shaft is recommended.

NOTE: Consult Nexen in the following situations: a) before using a motor with an interrupted pilot; b) applications in which liquids or excessive dust are present and may ingress into the product.

Heat Dissipation

To dissipate heat generated by the motor, Nexen recommends mounting the gearhead to a machine frame or heat sink. Refer to the table at the right for aluminum heat sink plate sizes used in testing by Nexen.

Heat Sink Surface Area (m ²)			
HG(P)17	HG(P)25	HG(P)32	HG(P)50
0.11	0.14	0.14	0.27

HGP Preloader

Pair Nexen's Harmonic Gearhead with our HG Preloader for easy integration into your machine design. Preloaders feature an adjuster that allows the HGP to be moved up or down into the rack while keeping the pinion properly oriented to the rack.

Preloader components are made of an alloy steel with a corrosion-resistant nickel finish.

- High-Precision Ground Surfaces
- Allows Perpendicular Movement
- Corrosion Resistant Materials

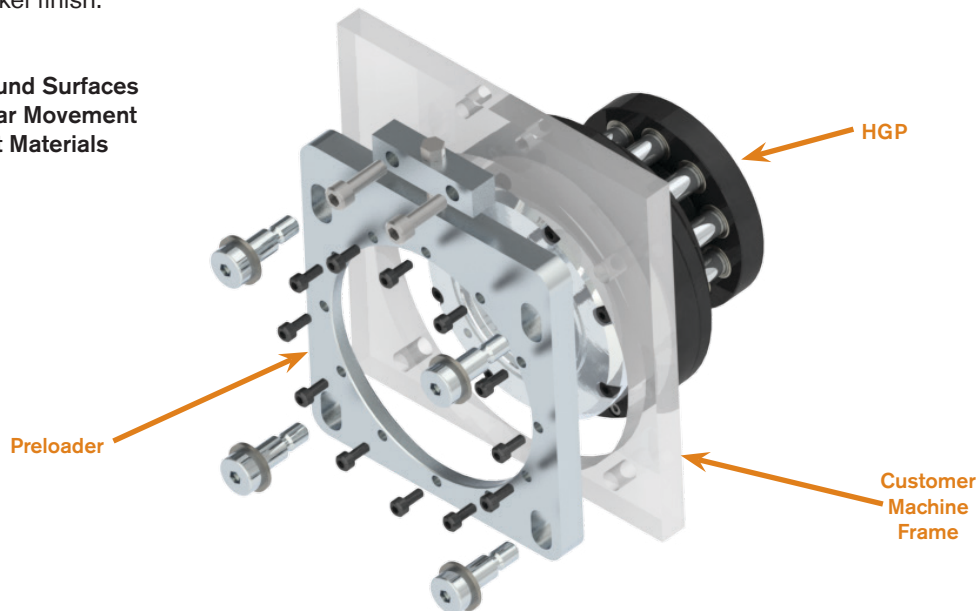

HGP Preloader Dimensional Drawings

HGP17 Product Number 960870

All dimensions shown in mm.

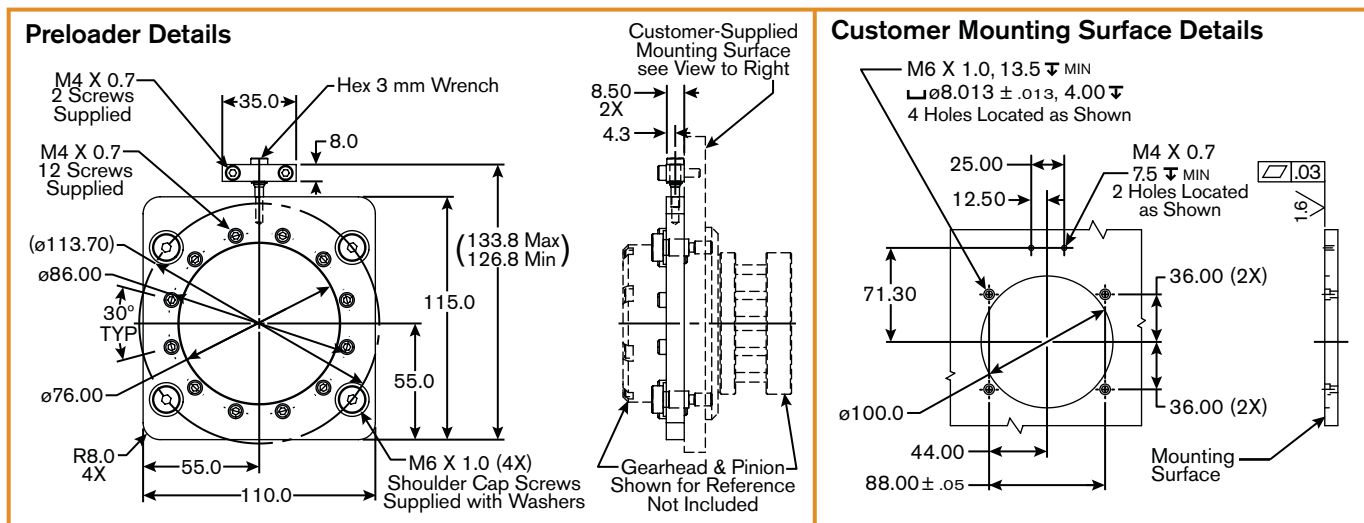

Harmonic Gearhead
Preloader

HGP Preloader Dimensional Drawings (continued)

HGP25 Product Number 960872

All dimensions shown in mm.

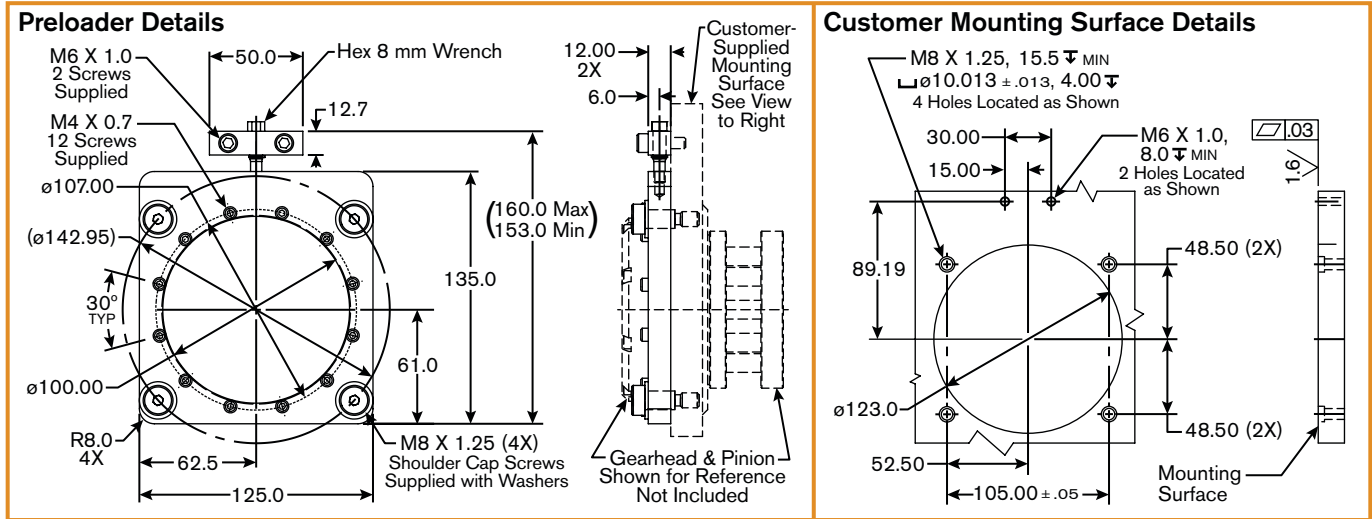

HGP32 Product Number 960873

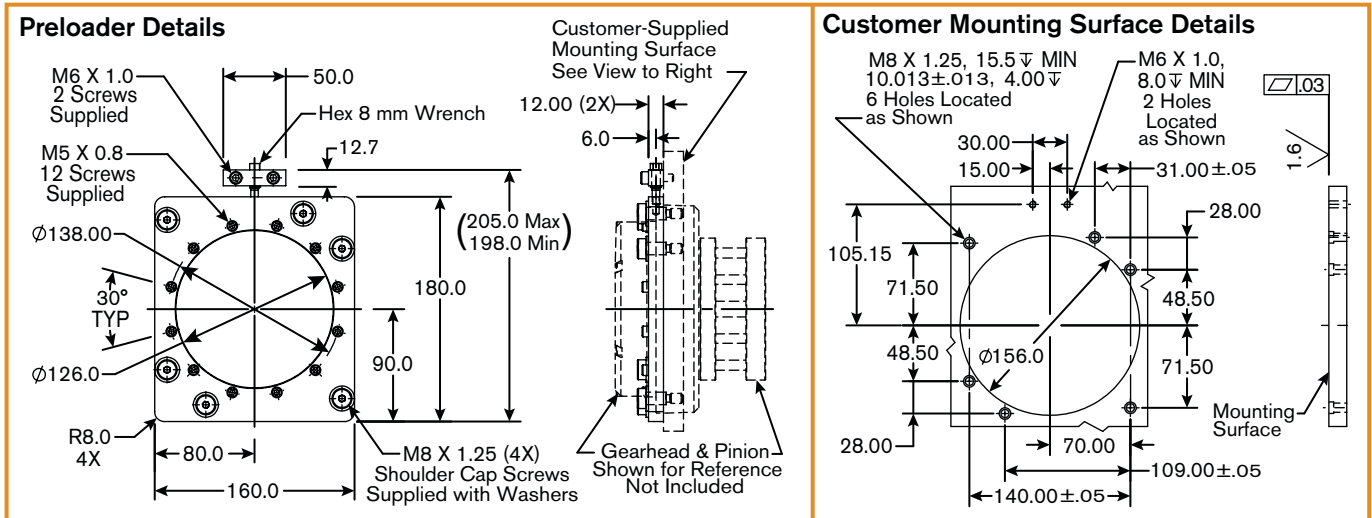

HGP50 Product Number 960875

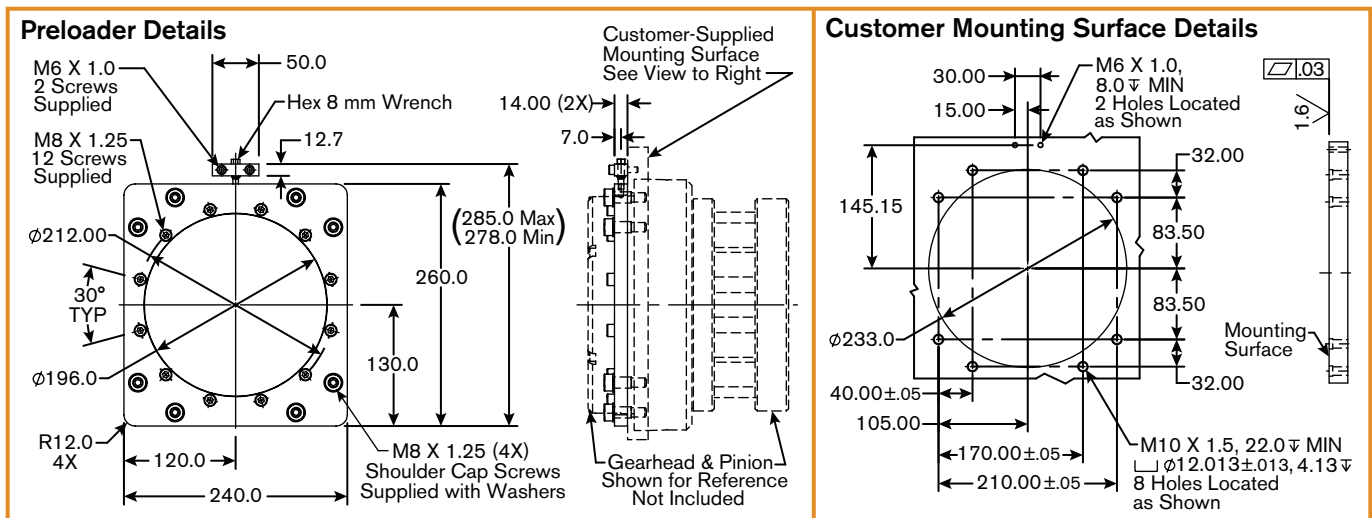

Harmonic Gearhead Preloader